



- VFFS Bagger Machine
- Multihead Weigher Packaging Machine
- Auger Filler Packaging Machine
- Cup Filler Packaging Machine
- Manual Filler Machine
- Conveyor

**We Pack
the World
for you**



Spices

Chips



**flexible pouch packaging machines
Very High Speed**



Grains

**Accurate
Versatile & Customise**



LEEON ENGINEERS

Packaging Solution

Multi-head Weighing Packaging Machine

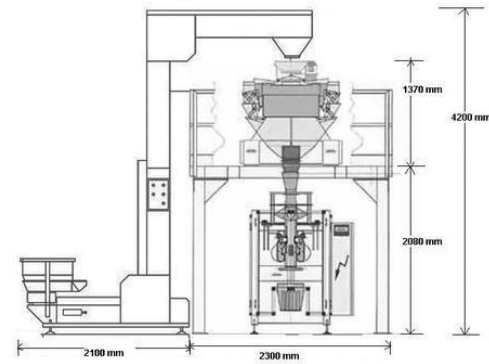

Multi-head Weighing Machine

- Japanese PLC controller & touch screen HMI equipped for automation.
- AC motor driven bag length control mechanism
- Quick & easy size change over



Application With Fillers:



Applications: Potato Chips, Kurkure, Macroni,
Namkeens, Dry Fruits, Nuts, Candies,
Fryums seeds, tea, pasta,
Any kind of things in granules Form

Upto(5gm to 1kg)

**Quality, Comfort
& Peace of mind**

Multi-head Packaging Machine Specification:

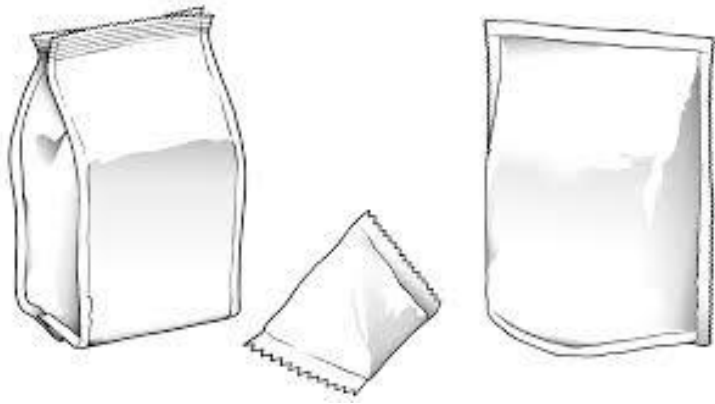

Pouch Type



Technical Specifications

Bagger Speed (up to)	80 Bag/min
Quantity	Up to 5 kg
Pack Size Range	
Min. Pouch Size (W X L)	50mm x 75mm
Max. Pouch Size (W X L)	400mm x 600mm
Horizontal/Vertical Table	Pneumatically Driven (Servo Motor driven optionavailable)
Packaging Material	Heat Selable Laminate
Heat System	Constant Through Heater
Supply Voltage	Stabilized 415V AC, 3 Phase, 50 Hz
Connected Load	4kw
Air consuption	35 m/hr @ 6 bar
Machine Body/Contact Parts	M.S With powder coated /Stainless Steel (Contact Parts)
Pneumatic Type	Janetics / Festo / SMC
Servo Types	Mitshubishi / Schneider

Auger Filler Packaging Machine

THINK
in new
Dimensions

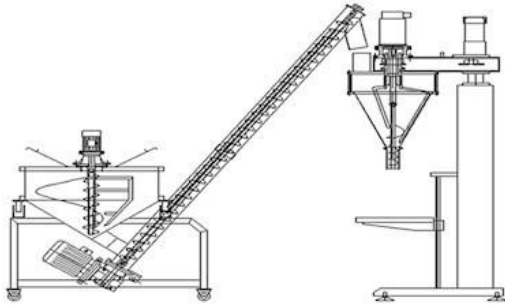

Auger Filler Machine

- Japanese PLC controller & touch screen HMI equipped for automation.
- AC motor driven bag length control mechanism
- Quick & easy size change over

Application With Fillers:

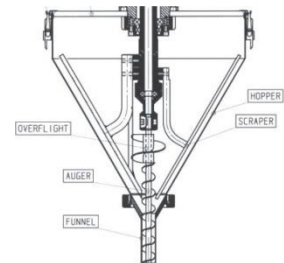

Applications: Spices, Atta (flour Products)
Milk Powder, Nutraceuticals
Coffee Powder, Premixes, Instant
mixes, Garam masala, coriander
Powder (etc).

Upto(5gm to 1kg)

Auger filler Packaging Machine Specification:



Technical Specifications

Bagger Speed (up to)	80 Bag/min
Quantity	Up to 5 kg
Pack Size Range	
Min. Pouch Size (W X L)	50mm x 75mm
Max. Pouch Size (W X L)	400mm x 600mm
Horizontal/Vertical Table	Pneumatically Driven (Servo Motor driven optionavailable)
Packaging Material	Heat Selable Laminate
Heat System	Constant Through Heater
Supply Voltage	Stabilized 415V AC, 3 Phase, 50 Hz
Connected Load	4kw
Air consumption	35 m/hr @ 6 bar
Machine Body/Contact Parts	M.S With powder coated /Stainless Steel (Contact Parts)
Pneumatic Type	Janetics / Festo / SMC
Servo Types	Mitshubishi / Schneider
Filling Sysytem	Auger Filler

Cup Filler Packaging Machine

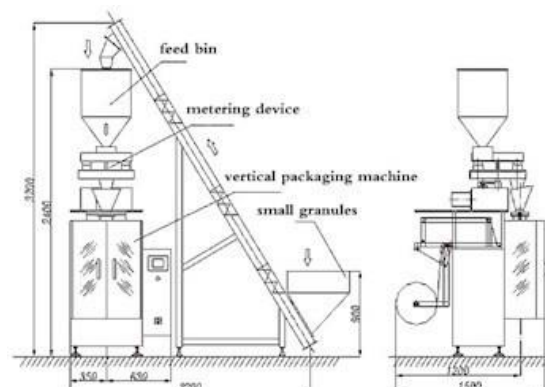

Cup Filling Machine

- Japanese PLC controller & touch screen HMI equipped for automation.
- AC motor driven bag length control mechanism
- Quick & easy size change over
- Cup filling



Application With Fillers:

Applications: Spices, Atta (flour Products)
Milk Powder, Nutraceuticals
Coffee Powder, Premix powder,
Instant mixes, Gram Powder,
Coriander Powder (etc).

Upto(5gm to 1kg)



**The Best Grains
TO TRY WITH
PALEO**



Cup filler Packaging Machine Specifications:



Technical Specifications

Bagger Speed (up to)	70 Bag/min
Quantity	Up to 1 kg
Pack Size Range	
Min. Pouch Size (W X L)	50mm x 75mm
Max. Pouch Size (W X L)	400mm x 600mm
Horizontal/Vertical Table	Pneumatically Driven (Servo Motor driven optionavailable)
Packaging Material	Heat Selable Laminate
Heat System	Constant Through Heater
Supply Voltage	Stabilized 415V AC, 3 Phase, 50 Hz
Connected Load	4kw
Air consumption	35 m/hr @ 6 bar
Machine Body/Contact Parts	M.S With powder coated /Stainless Steel (Contact Parts)
Pneumatic Type	Janetics / Festo / SMC
Servo Types	Mitshubishi / Schneider
Filling Sysytem	Cup Filler

Liquid Packaging Machine Specifications:

We Define
Perfection



CLIENT DETAILS :



DESH KI SEHAT
DESH KA NAMAK



MAGNAM NETLINK PVT. LTD.
Building business connection



**SenTech
Automation**



Other Valuable Customers



- Bajarang Namkeen
- B Z Food
- Patel Foods
- Smart Gruh Udhyod
- Khilkhilat Namkeen
- Mruti Namkeen

Machine Additional Fitting



Incline Elevator



Z Type Bucket Elevator



Belt Conveyor



Screw Conveyor

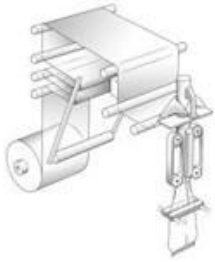

 **Quality** you
can **measure**

Terms & Condition :

1. Speed and accuracy mentioned are ideal condition and may vary depending upon production being and packaging material used
2. We reserve the right to incorporate changes, modify and upgrade as found appropriate for specific application for packaging so to fine tune the product with machine.
3. Specification are subject to change without notice



Himal Patel

+91 9574662692

+91 9712334861

Address :

LEEON ENGINEERS
991/3/A, Behind Gayatri Ice Factory
GIDG, Makarpura, Vadodara-390010

Web: WWW.LEEONENGINEERS.COM

Email : leeonengineers08@gmail.com
salesleon08@gmail.com